



सामान्य निर्देश :

निम्नलिखित निर्देशों को बहुत सावधानी से पढ़िए और उनका सख्ती से पालन कीजिए :

- (i) इस प्रश्न-पत्र में 38 प्रश्न हैं। सभी प्रश्न अनिवार्य हैं।
- (ii) यह प्रश्न-पत्र पाँच खण्डों में विभाजित है – क, ख ग, घ एवं ङ।
- (iii) खण्ड क में प्रश्न संख्या 1 से 18 तक बहुविकल्पीय (MCQ) तथा प्रश्न संख्या 19 एवं 20 अभिकथन एवं तर्क आधारित 1 अंक के प्रश्न हैं।
- (iv) खण्ड ख में प्रश्न संख्या 21 से 25 तक अति लघु-उत्तरीय (VSA) प्रकार के 2 अंकों के प्रश्न हैं।
- (v) खण्ड ग में प्रश्न संख्या 26 से 31 तक लघु-उत्तरीय (SA) प्रकार के 3 अंकों के प्रश्न हैं।
- (vi) खण्ड घ में प्रश्न संख्या 32 से 35 तक दीर्घ-उत्तरीय (LA) प्रकार के 5 अंकों के प्रश्न हैं।
- (vii) खण्ड ङ में प्रश्न संख्या 36 से 38 तक प्रकरण अध्ययन आधारित 4 अंकों के प्रश्न हैं।
- (viii) प्रश्न-पत्र में समग्र विकल्प नहीं दिया गया है। यद्यपि, खण्ड ख के 2 प्रश्नों में, खण्ड ग के 3 प्रश्नों में, खण्ड घ के 2 प्रश्नों में तथा खण्ड ङ के 2 प्रश्नों में आंतरिक विकल्प का प्रावधान दिया गया है।
- (ix) कैल्कुलेटर का उपयोग वर्जित है।

खण्ड क

इस खण्ड में 20 बहुविकल्पीय प्रश्न हैं, जिनमें प्रत्येक प्रश्न 1 अंक का है।

$20 \times 1 = 20$

1. यदि A तथा B दो, कोटि 2 के वर्ग आव्यूह हैं तथा $|A| = 2$ और $|B| = 5$ है, तो $|-3AB|$ है :

- (A) -90 (B) -30
(C) 30 (D) 90

2. $\int \frac{x-3}{(x-1)^3} e^x dx$ बराबर है :

- (A) $\frac{2e^x}{(x-1)^3} + C$ (B) $\frac{-2e^x}{(x-1)^2} + C$
(C) $\frac{e^x}{(x-1)} + C$ (D) $\frac{e^x}{(x-1)^2} + C$





General Instructions :

Read the following instructions very carefully and strictly follow them :

- (i) This question paper contains **38** questions. **All** questions are **compulsory**.
- (ii) This question paper is divided into **five** Sections – **A, B, C, D** and **E**.
- (iii) In **Section A**, Questions no. **1** to **18** are Multiple Choice Questions (MCQs) and questions number **19** and **20** are Assertion-Reason based questions of **1** mark each.
- (iv) In **Section B**, Questions no. **21** to **25** are Very Short Answer (VSA) type questions, carrying **2** marks each.
- (v) In **Section C**, Questions no. **26** to **31** are Short Answer (SA) type questions, carrying **3** marks each.
- (vi) In **Section D**, Questions no. **32** to **35** are Long Answer (LA) type questions carrying **5** marks each.
- (vii) In **Section E**, Questions no. **36** to **38** are case study based questions carrying **4** marks each.
- (viii) There is no overall choice. However, an internal choice has been provided in 2 questions in Section B, 3 questions in Section C, 2 questions in Section D and 2 questions in Section E.
- (ix) Use of calculator is **not** allowed.

SECTION A

This section comprises 20 Multiple Choice Questions (MCQs) carrying **1** mark each. $20 \times 1 = 20$

1. If A and B are two square matrices of order 2 and $|A| = 2$ and $|B| = 5$, then $|-3AB|$ is :

- (A) -90
- (B) -30
- (C) 30
- (D) 90

2. $\int \frac{x-3}{(x-1)^3} e^x dx$ is equal to :

- (A) $\frac{2e^x}{(x-1)^3} + C$
- (B) $\frac{-2e^x}{(x-1)^2} + C$
- (C) $\frac{e^x}{(x-1)} + C$
- (D) $\frac{e^x}{(x-1)^2} + C$





3. वक्र $y = x$, x -अक्ष, $x = 0$ तथा $x = 2$ से घिरे क्षेत्र का क्षेत्रफल (वर्ग इकाइयों में) है :
- (A) $\frac{3}{2}$ (B) $\frac{1}{2} \log 2$
(C) 2 (D) 4
4. सदिशों $\vec{a} = 2\hat{i} - 3\hat{j} - 6\hat{k}$ तथा $\vec{b} = 2\hat{i} - 2\hat{j} + \hat{k}$ के लिए $\frac{\vec{a} \text{ का } \vec{b} \text{ पर प्रक्षेप}}{\vec{b} \text{ का } \vec{a} \text{ पर प्रक्षेप}}$ का मान क्या है ?
- (A) $\frac{3}{7}$ (B) $\frac{7}{3}$
(C) $\frac{4}{3}$ (D) $\frac{4}{7}$
5. यदि \vec{a} तथा \vec{b} दो ऐसे सदिश हैं कि $\vec{a} \cdot \vec{b} > 0$ है तथा $|\vec{a} \cdot \vec{b}| = |\vec{a} \times \vec{b}|$ है, तो \vec{a} तथा \vec{b} के बीच का कोण है :
- (A) $\frac{\pi}{4}$ (B) $\frac{\pi}{3}$
(C) $\frac{2\pi}{3}$ (D) $\frac{3\pi}{4}$
6. दो आव्यूह A तथा B के लिए दिया गया है कि $A^{-1} = \frac{1}{4}B$, तो $(4A)$ का व्युत्क्रम है :
- (A) $4B$ (B) B
(C) $\frac{1}{4}B$ (D) $\frac{1}{16}B$
7. यदि $x = at^2$ तथा $y = 2at$ है, तो $\frac{dy}{dx}$ बराबर है :
- (A) $2at$ (B) $\frac{1}{t}$
(C) $-\frac{1}{t^2}$ (D) $-\frac{1}{2at^3}$
8. फलन $f(x) = |x| - x$ जहाँ $x \in \mathbb{R}$, $x = 0$ पर :
- (A) संतत तथा अवकलनीय है
(B) संतत है परन्तु अवकलनीय नहीं है
(C) संतत नहीं है परन्तु अवकलनीय है
(D) न तो संतत है और न ही अवकलनीय है





3. The area (in sq. units) of the region bounded by the curve $y = x$, x -axis, $x = 0$ and $x = 2$ is :
- (A) $\frac{3}{2}$ (B) $\frac{1}{2} \log 2$
(C) 2 (D) 4
4. What is the value of $\frac{\text{projection of } \vec{a} \text{ on } \vec{b}}{\text{projection of } \vec{b} \text{ on } \vec{a}}$ for vectors $\vec{a} = 2\hat{i} - 3\hat{j} - 6\hat{k}$ and $\vec{b} = 2\hat{i} - 2\hat{j} + \hat{k}$?
- (A) $\frac{3}{7}$ (B) $\frac{7}{3}$
(C) $\frac{4}{3}$ (D) $\frac{4}{7}$
5. If \vec{a} and \vec{b} are two vectors such that $\vec{a} \cdot \vec{b} > 0$ and $|\vec{a} \cdot \vec{b}| = |\vec{a} \times \vec{b}|$, then the angle between \vec{a} and \vec{b} is :
- (A) $\frac{\pi}{4}$ (B) $\frac{\pi}{3}$
(C) $\frac{2\pi}{3}$ (D) $\frac{3\pi}{4}$
6. For two matrices A and B, given that $A^{-1} = \frac{1}{4}B$, then inverse of $(4A)$ is :
- (A) $4B$ (B) B
(C) $\frac{1}{4}B$ (D) $\frac{1}{16}B$
7. If $x = at^2$ and $y = 2at$, then $\frac{dy}{dx}$ is equal to :
- (A) $2at$ (B) $\frac{1}{t}$
(C) $-\frac{1}{t^2}$ (D) $-\frac{1}{2at^3}$
8. The function $f(x) = |x| - x$ where $x \in \mathbb{R}$ is :
- (A) continuous and differentiable at $x = 0$
(B) continuous but not differentiable at $x = 0$
(C) not continuous but differentiable at $x = 0$
(D) neither continuous nor differentiable at $x = 0$





9. यदि X, Y तथा XY क्रमशः $2 \times 3, m \times n$ तथा 2×5 कोटि के आव्यूह हैं, तो आव्यूह Y के अवयवों की संख्या है :

- (A) 6 (B) 10
(C) 15 (D) 35

10. $f(x) = \begin{cases} x+2, & \text{यदि } x < 0 \\ e^x, & \text{यदि } 0 \leq x \leq 1 \\ 2-x, & \text{यदि } x > 1 \end{cases}$ द्वारा प्रदत्त फलन f के असांतत्य बिंदुओं की संख्या है :

- (A) 0 (B) 1
(C) 2 (D) 3

11. $\int e^{3 \log x} (x^4 + 1)^{-1} dx$ बराबर है :

- (A) $\frac{1}{4} \log (x^4 + 1) + C$
(B) $\frac{1}{4} \log \left(\frac{1}{x^4 + 1} \right) + C$
(C) $\frac{x^3}{x^4 + 1} + C$
(D) $\frac{e^x}{x^4 + 1} + C$

12. माना $y = f\left(\frac{1}{x}\right)$ तथा $f'(x) = x^3$ है, तो $x = \frac{1}{2}$ पर $\frac{dy}{dx}$ का मान क्या है ?

- (A) $-\frac{1}{64}$ (B) $-\frac{1}{32}$
(C) -32 (D) -64



9. If X , Y and XY are matrices of order 2×3 , $m \times n$ and 2×5 respectively, then number of elements in matrix Y is :

- (A) 6 (B) 10
(C) 15 (D) 35

10. The number of discontinuities of the function f given by

$$f(x) = \begin{cases} x + 2, & \text{if } x < 0 \\ e^x, & \text{if } 0 \leq x \leq 1 \\ 2 - x, & \text{if } x > 1 \end{cases}$$

is :

- (A) 0 (B) 1
(C) 2 (D) 3

11. $\int e^{3 \log x} (x^4 + 1)^{-1} dx$ is equal to :

- (A) $\frac{1}{4} \log (x^4 + 1) + C$
(B) $\frac{1}{4} \log \left(\frac{1}{x^4 + 1} \right) + C$
(C) $\frac{x^3}{x^4 + 1} + C$
(D) $\frac{e^x}{x^4 + 1} + C$

12. Let $y = f\left(\frac{1}{x}\right)$ and $f'(x) = x^3$. What is the value of $\frac{dy}{dx}$ at $x = \frac{1}{2}$?

- (A) $-\frac{1}{64}$ (B) $-\frac{1}{32}$
(C) -32 (D) -64





13. यदि $y = \log \sqrt{\sec \sqrt{x}}$ है, तो $x = \frac{\pi^2}{16}$ पर $\frac{dy}{dx}$ का मान है :

(A) $\frac{1}{\pi}$

(B) π

(C) $\frac{1}{2}$

(D) $\frac{1}{4}$

14. अवकल समीकरण $x \frac{dy}{dx} + y = 0$ का एक विशिष्ट हल, जब $x = 1$ और $y = 1$ है, है :

(A) $y = x$

(B) $y = e^x$

(C) $y = \frac{1}{x}$

(D) $y = \log x$

15. $f(x) = [x]$, $1 < x < 3$ द्वारा परिभाषित महत्तम पूर्णांक फलन जिस बिंदु पर अवकलनीय नहीं है, वह है $x =$

(A) 0

(B) 1

(C) 2

(D) $\frac{3}{2}$

16. एक सदिश x , y तथा z -अक्षों की धनात्मक दिशाओं से समान कोण बनाता है। इस सदिश के दिक्-कोसाइन हैं :

(A) $\frac{1}{\sqrt{3}}, \frac{1}{\sqrt{3}}, \frac{1}{\sqrt{3}}$

(B) $\frac{-1}{\sqrt{3}}, \frac{-1}{\sqrt{3}}, \frac{1}{\sqrt{3}}$

(C) $\frac{-1}{2}, \frac{1}{2}, \frac{-1}{2}$

(D) $\frac{1}{\sqrt{6}}, \frac{1}{\sqrt{6}}, \frac{-2}{\sqrt{6}}$



13. If $y = \log \sqrt{\sec \sqrt{x}}$, then the value of $\frac{dy}{dx}$ at $x = \frac{\pi^2}{16}$ is :
- (A) $\frac{1}{\pi}$ (B) π
(C) $\frac{1}{2}$ (D) $\frac{1}{4}$
14. A particular solution of the differential equation $x \frac{dy}{dx} + y = 0$, when $x = 1$ and $y = 1$, is :
- (A) $y = x$
(B) $y = e^x$
(C) $y = \frac{1}{x}$
(D) $y = \log x$
15. The greatest integer function defined by $f(x) = [x]$, $1 < x < 3$ is not differentiable at $x =$
- (A) 0 (B) 1
(C) 2 (D) $\frac{3}{2}$
16. A vector makes equal angles with positive directions of x , y and z axes. The direction cosines of the vector are :
- (A) $\frac{1}{\sqrt{3}}, \frac{1}{\sqrt{3}}, \frac{1}{\sqrt{3}}$
(B) $\frac{-1}{\sqrt{3}}, \frac{-1}{\sqrt{3}}, \frac{1}{\sqrt{3}}$
(C) $\frac{-1}{2}, \frac{1}{2}, \frac{-1}{2}$
(D) $\frac{1}{\sqrt{6}}, \frac{1}{\sqrt{6}}, \frac{-2}{\sqrt{6}}$





17. बिंदुओं (0, 0, 2) तथा (3, -2, 5) से होकर जाने वाली रेखा का सदिश समीकरण है :

(A) $\vec{r} = 2\hat{k} + \lambda(3\hat{i} + 2\hat{j} - 5\hat{k})$

(B) $\vec{r} = 2\hat{k} + \lambda(3\hat{i} - 2\hat{j} + 5\hat{k})$

(C) $\vec{r} = 2\hat{k} + \lambda(3\hat{i} - 2\hat{j} + 3\hat{k})$

(D) $\vec{r} = 3\hat{i} - 2\hat{j} + 5\hat{k} + \lambda(2\hat{k})$

18. यदि एक वृत्त की त्रिज्या 0.5 cm/s की दर से बढ़ रही है, तो इसकी परिधि के बढ़ने की दर है :

(A) $\frac{2\pi}{3}$ cm/s

(B) π cm/s

(C) $\frac{4\pi}{3}$ cm/s

(D) 2π cm/s

प्रश्न संख्या 19 और 20 अभिकथन एवं तर्क आधारित प्रश्न हैं। दो कथन दिए गए हैं जिनमें एक को अभिकथन (A) तथा दूसरे को तर्क (R) द्वारा अंकित किया गया है। इन प्रश्नों के सही उत्तर नीचे दिए गए कोडों (A), (B), (C) और (D) में से चुनकर दीजिए।

(A) अभिकथन (A) और तर्क (R) दोनों सही हैं और तर्क (R), अभिकथन (A) की सही व्याख्या करता है।

(B) अभिकथन (A) और तर्क (R) दोनों सही हैं, परन्तु तर्क (R), अभिकथन (A) की सही व्याख्या नहीं करता है।

(C) अभिकथन (A) सही है, परन्तु तर्क (R) गलत है।

(D) अभिकथन (A) गलत है, परन्तु तर्क (R) सही है।

19. अभिकथन (A) : यदि R तथा S दो ऐसी घटनाएँ हैं कि $P(R | S) = 1$ और $P(S) > 0$ है, तो $S \subset R$.

तर्क (R) : यदि दो घटनाएँ A तथा B ऐसी हैं कि $P(A \cap B) = P(B)$ है, तो $A \subset B$.

20. अभिकथन (A) : $\cos^{-1}\left(\cos\frac{13\pi}{6}\right), \frac{\pi}{6}$ के बराबर है।

तर्क (R) : फलन $y = \cos^{-1} x$ की मुख्य मान शाखा का परिसर $[0, \pi]$ है।



17. The vector equation of the line passing through the points (0, 0, 2) and (3, -2, 5) is :

(A) $\vec{r} = 2\hat{k} + \lambda(3\hat{i} + 2\hat{j} - 5\hat{k})$

(B) $\vec{r} = 2\hat{k} + \lambda(3\hat{i} - 2\hat{j} + 5\hat{k})$

(C) $\vec{r} = 2\hat{k} + \lambda(3\hat{i} - 2\hat{j} + 3\hat{k})$

(D) $\vec{r} = 3\hat{i} - 2\hat{j} + 5\hat{k} + \lambda(2\hat{k})$

18. If the radius of a circle is increasing at the rate of 0.5 cm/s, then the rate of increase of its circumference is :

(A) $\frac{2\pi}{3}$ cm/s

(B) π cm/s

(C) $\frac{4\pi}{3}$ cm/s

(D) 2π cm/s

Questions number 19 and 20 are Assertion and Reason based questions. Two statements are given, one labelled Assertion (A) and the other labelled Reason (R). Select the correct answer from the codes (A), (B), (C) and (D) as given below.

(A) Both Assertion (A) and Reason (R) are true and Reason (R) is the correct explanation of the Assertion (A).

(B) Both Assertion (A) and Reason (R) are true, but Reason (R) is **not** the correct explanation of the Assertion (A).

(C) Assertion (A) is true, but Reason (R) is false.

(D) Assertion (A) is false, but Reason (R) is true.

19. Assertion (A) : If R and S are two events such that $P(R | S) = 1$ and $P(S) > 0$, then $S \subset R$.

Reason (R) : If two events A and B are such that $P(A \cap B) = P(B)$, then $A \subset B$.

20. Assertion (A) : $\cos^{-1} \left(\cos \frac{13\pi}{6} \right)$ is equal to $\frac{\pi}{6}$.

Reason (R) : The range of the principal value branch of the function $y = \cos^{-1} x$ is $[0, \pi]$.



खण्ड ख

इस खण्ड में अति लघु-उत्तरीय (VSA) प्रकार के प्रश्न हैं, जिनमें प्रत्येक के 2 अंक हैं।

21. मान ज्ञात कीजिए :

$$\sin^{-1} \left(\sin \frac{13\pi}{6} \right) + \cos^{-1} \left(\cos \frac{\pi}{3} \right) + \tan^{-1} (\sqrt{3})$$

22. दिया गया है कि $f(x) = \frac{\log x}{x}$ है, तो $f(x)$ का स्थानीय उच्चतम बिंदु ज्ञात कीजिए।

23. (क) ज्ञात कीजिए :

$$\int \frac{x^3 - 1}{x^3 - x} dx$$

अथवा

(ख) ज्ञात कीजिए :

$$\int_{-4}^0 |x + 2| dx$$

24. (क) यदि $y = (\sin^{-1} x)^2$ है, तो $(1 - x^2) \frac{d^2 y}{dx^2} - x \frac{dy}{dx}$ ज्ञात कीजिए।

अथवा

(ख) यदि $y^x = x^y$ है, तो $\frac{dy}{dx}$ ज्ञात कीजिए।

25. k का वह मान ज्ञात कीजिए जिससे बिंदुओं $(1, -1, 2)$ तथा $(3, 4, k)$ को मिलाने वाली रेखाएँ बिंदुओं $(0, 3, 2)$ तथा $(3, 5, 6)$ को मिलाने वाली रेखा के लंबवत् हो।



SECTION B

This section comprises Very Short Answer (VSA) type questions of 2 marks each.

21. Evaluate :

$$\sin^{-1} \left(\sin \frac{13\pi}{6} \right) + \cos^{-1} \left(\cos \frac{\pi}{3} \right) + \tan^{-1} (\sqrt{3})$$

22. Given that $f(x) = \frac{\log x}{x}$, find the point of local maximum of $f(x)$.

23. (a) Find :

$$\int \frac{x^3 - 1}{x^3 - x} dx$$

OR

(b) Evaluate :

$$\int_{-4}^0 |x + 2| dx$$

24. (a) If $y = (\sin^{-1} x)^2$, then find $(1 - x^2) \frac{d^2 y}{dx^2} - x \frac{dy}{dx}$.

OR

(b) If $y^x = x^y$, then find $\frac{dy}{dx}$.

25. Find the value of k so that the lines joining the points $(1, -1, 2)$ and $(3, 4, k)$ is perpendicular to the line joining the points $(0, 3, 2)$ and $(3, 5, 6)$.



खण्ड ग

इस खण्ड में लघु-उत्तरीय (SA) प्रकार के प्रश्न हैं, जिनमें प्रत्येक के 3 अंक हैं।

26. यह ज्ञात है कि एक विद्यालय के 20% छात्रों की उपस्थिति 90% से अधिक है और 80% छात्र अनियमित हैं। पिछले वर्ष के परिणाम दर्शाते हैं कि 80% छात्र जिनकी उपस्थिति 90% से अधिक है तथा 20% अनियमित छात्रों ने वार्षिक परीक्षा में 'A' ग्रेड प्राप्त किया। वर्ष के अन्त में, विद्यालय के छात्रों में से यादृच्छया एक छात्र चुना गया तथा यह पाया गया कि उसने 'A' ग्रेड प्राप्त किया है। क्या प्रायिकता है कि चुना गया छात्र अनियमित है ?

27. (क) यदि $y = \cos^{-1} \left(\frac{1-x^2}{1+x^2} \right)$, $0 < x < 1$ है, तो $\frac{dy}{dx}$ ज्ञात कीजिए।

अथवा

(ख) यदि $x^y = e^{x-y}$ है, तो सिद्ध कीजिए कि $\frac{dy}{dx} = \frac{\log x}{\{\log(xe)\}^2}$.

28. (क) यदि $A \begin{bmatrix} 4 & 0 \\ -1 & -2 \end{bmatrix} = \begin{bmatrix} 17 & 10 \\ 0 & -16 \end{bmatrix}$ है, तो आव्यूह A ज्ञात कीजिए।

A^{-1} भी ज्ञात कीजिए।

अथवा

(ख) दिया गया है कि A एक कोटि 3 का वर्ग आव्यूह है तथा $A^2 = \begin{bmatrix} 3 & -4 & 4 \\ 0 & -1 & 0 \\ -2 & 2 & -3 \end{bmatrix}$ है,

दर्शाएँ कि $A^3 = A^{-1}$.

29. अवकल समीकरण $x \cos y \, dy = (x e^x \log x + e^x) \, dx$ का विशिष्ट हल ज्ञात कीजिए, दिया गया है कि $y = \frac{\pi}{2}$ है जब $x = 1$ है।

30. दर्शाएँ कि सदिश $3\hat{i} + \hat{j} - 2\hat{k}$, $2\hat{i} - \hat{j} - 8\hat{k}$ तथा $4\hat{i} - 2\hat{j} - 7\hat{k}$ एक समकोण त्रिभुज के शीर्ष हैं।

SECTION C

This section comprises Short Answer (SA) type questions of 3 marks each.

26. It is known that 20% of the students in a school have above 90% attendance and 80% of the students are irregular. Past year results show that 80% of students who have above 90% attendance and 20% of irregular students get 'A' grade in their annual examination. At the end of a year, a student is chosen at random from the school and is found to have an 'A' grade. What is the probability that the student is irregular ?

27. (a) If $y = \cos^{-1} \left(\frac{1-x^2}{1+x^2} \right)$, $0 < x < 1$, then find $\frac{dy}{dx}$.

OR

(b) If $xy = e^{x-y}$, prove that $\frac{dy}{dx} = \frac{\log x}{\{\log(xe)\}^2}$.

28. (a) Find a matrix A such that

$$A \begin{bmatrix} 4 & 0 \\ -1 & -2 \end{bmatrix} = \begin{bmatrix} 17 & 10 \\ 0 & -16 \end{bmatrix}.$$

Also, find A^{-1} .

OR

(b) Given a square matrix A of order 3 such that $A^2 = \begin{bmatrix} 3 & -4 & 4 \\ 0 & -1 & 0 \\ -2 & 2 & -3 \end{bmatrix}$,

show that $A^3 = A^{-1}$.

29. Find the particular solution of the differential equation :

$$x \cos y \, dy = (x e^x \log x + e^x) \, dx \quad \text{given that } y = \frac{\pi}{2} \text{ when } x = 1.$$

30. Show that the vectors $3\hat{i} + \hat{j} - 2\hat{k}$, $2\hat{i} - \hat{j} - 8\hat{k}$ and $4\hat{i} - 2\hat{j} - 7\hat{k}$ form the vertices of a right triangle.





31. (क) ज्ञात कीजिए :

$$\int \frac{dx}{\cos x \sqrt{\cos 2x}}$$

अथवा

(ख) ज्ञात कीजिए :

$$\int \frac{5x - 3}{\sqrt{1 + 4x - 2x^2}} dx$$

खण्ड घ

इस खण्ड में दीर्घ-उत्तरीय (LA) प्रकार के प्रश्न हैं, जिनमें प्रत्येक के 5 अंक हैं।

32. जाँच कीजिए कि क्या वास्तविक संख्याओं के समुच्चय \mathbb{R} में $S = \{(a, b) : a \leq b^2\}$ द्वारा परिभाषित संबंध S स्वतुल्य, सममित या संक्रामक है। वह सभी $x \in \mathbb{R}$ भी ज्ञात कीजिए जिनके लिए $(x, x) \in S$ है।

33. निम्नलिखित रैखिक प्रोग्रामन समस्या को आलेखीय विधि द्वारा हल कीजिए :

व्यवरोधों

$$x + 2y \geq 240$$

$$3x + 4y \leq 620$$

$$2x + y \geq 180$$

$$x, y \geq 0$$

के अंतर्गत $Z = 6x + 7y$ का न्यूनतमीकरण कीजिए।

34. (क) समाकलन के प्रयोग से, वक्र $y = \sqrt{4 - x^2}$, रेखाओं $x = -\sqrt{2}$ और $x = \sqrt{3}$ तथा x -अक्ष से घिरे क्षेत्र का क्षेत्रफल ज्ञात कीजिए।

अथवा

(ख) समाकलन के प्रयोग से, वक्र $y = x^2$, रेखाओं $y = 1$ तथा $y = 3$ और y -अक्ष से घिरे क्षेत्र का क्षेत्रफल ज्ञात कीजिए।





31. (a) Find :

$$\int \frac{dx}{\cos x \sqrt{\cos 2x}}$$

OR

(b) Find :

$$\int \frac{5x - 3}{\sqrt{1 + 4x - 2x^2}} dx$$

SECTION D

This section comprises Long Answer (LA) type questions of 5 marks each.

32. Check whether the relation S in the set \mathbb{R} of real numbers, defined as

$S = \{(a, b) : a \leq b^2\}$ is reflexive, symmetric or transitive. Also, determine all $x \in \mathbb{R}$ such that $(x, x) \in S$.

33. Solve the following linear programming problem graphically :

$$\text{Minimise } Z = 6x + 7y$$

subject to constraints

$$x + 2y \geq 240$$

$$3x + 4y \leq 620$$

$$2x + y \geq 180$$

$$x, y \geq 0.$$

34. (a) Using integration, find the area of the region bounded by the curve

$$y = \sqrt{4 - x^2}, \text{ the lines } x = -\sqrt{2} \text{ and } x = \sqrt{3} \text{ and the } x\text{-axis.}$$

OR

(b) Using integration, evaluate the area of the region bounded by the curve

$$y = x^2, \text{ the lines } y = 1 \text{ and } y = 3 \text{ and the } y\text{-axis.}$$





35. (क) रेखाओं $\frac{x-8}{3} = \frac{y+9}{-16} = \frac{z-10}{7}$ तथा $\frac{x-15}{3} = \frac{y-29}{8} = \frac{z-5}{-5}$ के बीच की न्यूनतम दूरी ज्ञात कीजिए।

अथवा

(ख) रेखाओं $\vec{r} = \hat{i} - \hat{j} + 6\hat{k} + \lambda(3\hat{i} - \hat{k})$ तथा $\vec{r} = -3\hat{j} + 3\hat{k} + \mu(\hat{i} + 2\hat{j} - \hat{k})$ का प्रतिच्छेदन बिंदु ज्ञात कीजिए। अतः एक अन्य रेखा का सदिश समीकरण ज्ञात कीजिए जो दी गई रेखाओं के प्रतिच्छेदन बिंदु से गुजरती है तथा उपर्युक्त दोनों रेखाओं के लंबवत् है।

खण्ड ड

इस खण्ड में 3 प्रकरण अध्ययन आधारित प्रश्न हैं, जिनमें प्रत्येक के 4 अंक हैं।

प्रकरण अध्ययन – 1

36. एक वास्तुकार एक व्यावसायिक परिसर के लिए भूमि का एक प्लॉट विकसित कर रहा है। जब उससे इसकी विमाओं के बारे में पूछा गया, तो उसने कहा कि यदि प्लॉट की लंबाई 25 m घटा दी जाए तथा चौड़ाई 25 m बढ़ा दी जाए, तो इसका क्षेत्रफल 625 m² बढ़ जाता है। यदि लंबाई 20 m घटा दी जाए तथा चौड़ाई 10 m बढ़ा दी जाए, तो इसका क्षेत्रफल 200 m² घट जाता है।

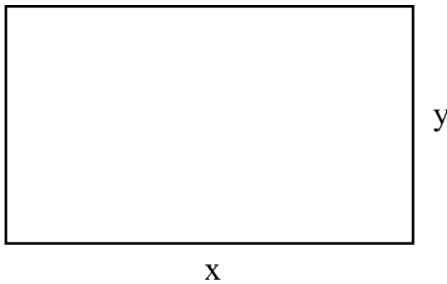

उपर्युक्त सूचना के आधार पर, निम्नलिखित प्रश्नों के उत्तर दीजिए :

- दी गई सूचना को दर्शाने के लिए x तथा y में रैखिक समीकरण बनाइए।
- आव्यूह विधि द्वारा भूमि के प्लॉट की विमाएँ ज्ञात कीजिए।





35. (a) Find the shortest distance between the lines $\frac{x-8}{3} = \frac{y+9}{-16} = \frac{z-10}{7}$ and $\frac{x-15}{3} = \frac{y-29}{8} = \frac{z-5}{-5}$.

OR

- (b) Find the point of intersection of the lines

$$\vec{r} = \hat{i} - \hat{j} + 6\hat{k} + \lambda(3\hat{i} - \hat{k}), \text{ and}$$

$$\vec{r} = -3\hat{j} + 3\hat{k} + \mu(\hat{i} + 2\hat{j} - \hat{k}).$$

Also, find the vector equation of the line passing through the point of intersection of the given lines and perpendicular to both the lines.

SECTION E

This section comprises 3 case study based questions of 4 marks each.

Case Study – 1

36. An architect is developing a plot of land for a commercial complex. When asked about the dimensions of the plot, he said that if the length is decreased by 25 m and the breadth is increased by 25 m, then its area increases by 625 m². If the length is decreased by 20 m and the breadth is increased by 10 m, then its area decreases by 200 m².

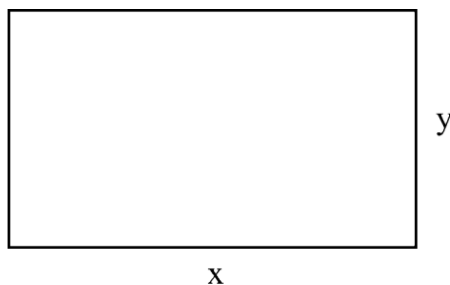

On the basis of the above information, answer the following questions :

- Formulate the linear equations in x and y to represent the given information.
- Find the dimensions of the plot of land by matrix method.



प्रकरण अध्ययन – 2

37. 60 मीटर की ऊँचाई पर स्थित एक गुब्बारे से एक रेत की बोरी गिराई गई।

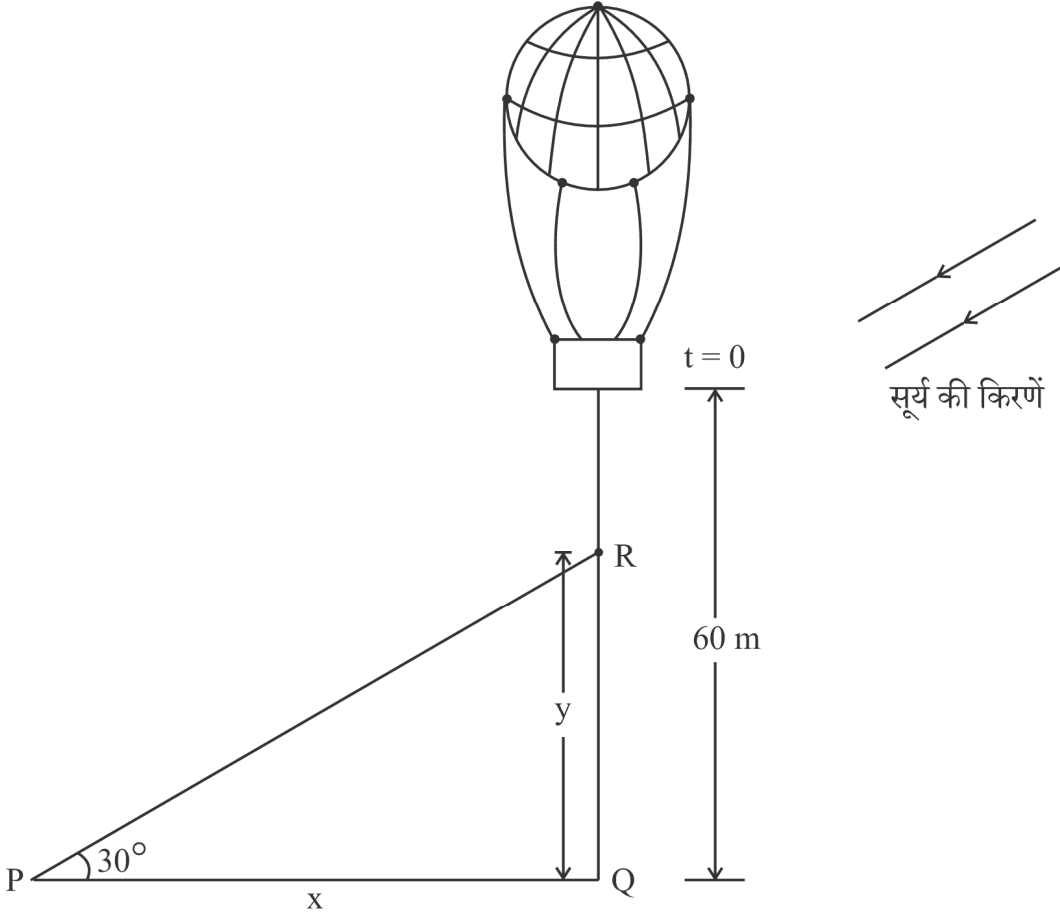

छाया पथ \rightarrow

जब सूर्य का उन्नतांश 30° है, रेत की बोरी का स्थिति समीकरण $y = 60 - 4.9 t^2$ द्वारा दी गई है, जहाँ y रेत की बोरी की भूमि से ऊपर की ऊँचाई दर्शाती है तथा t सेकण्डों में समय है।

उपर्युक्त सूचना के आधार पर, निम्नलिखित प्रश्नों के उत्तर दीजिए :

- x तथा y में संबंध ज्ञात कीजिए, जहाँ x , P पर पड़ रही छाया की बिंदु Q से दूरी है तथा y रेत की बोरी की भूमि से ऊपर की ऊँचाई है।
- कितने समय के बाद रेत की बोरी भूमि से 35 मीटर की ऊँचाई पर होगी ?
- (क) जब रेत की बोरी 35 मीटर की ऊँचाई पर है, उस समय रेत की बोरी की भूमि पर पड़ रही छाया की भूमि पर चलने की दर ज्ञात कीजिए।

अथवा

- (ख) 2 सेकण्ड निकल जाने के बाद रेत की बोरी की ऊँचाई के घटने की दर ज्ञात कीजिए।

Case Study – 2

37. A sandbag is dropped from a balloon at a height of 60 metres.

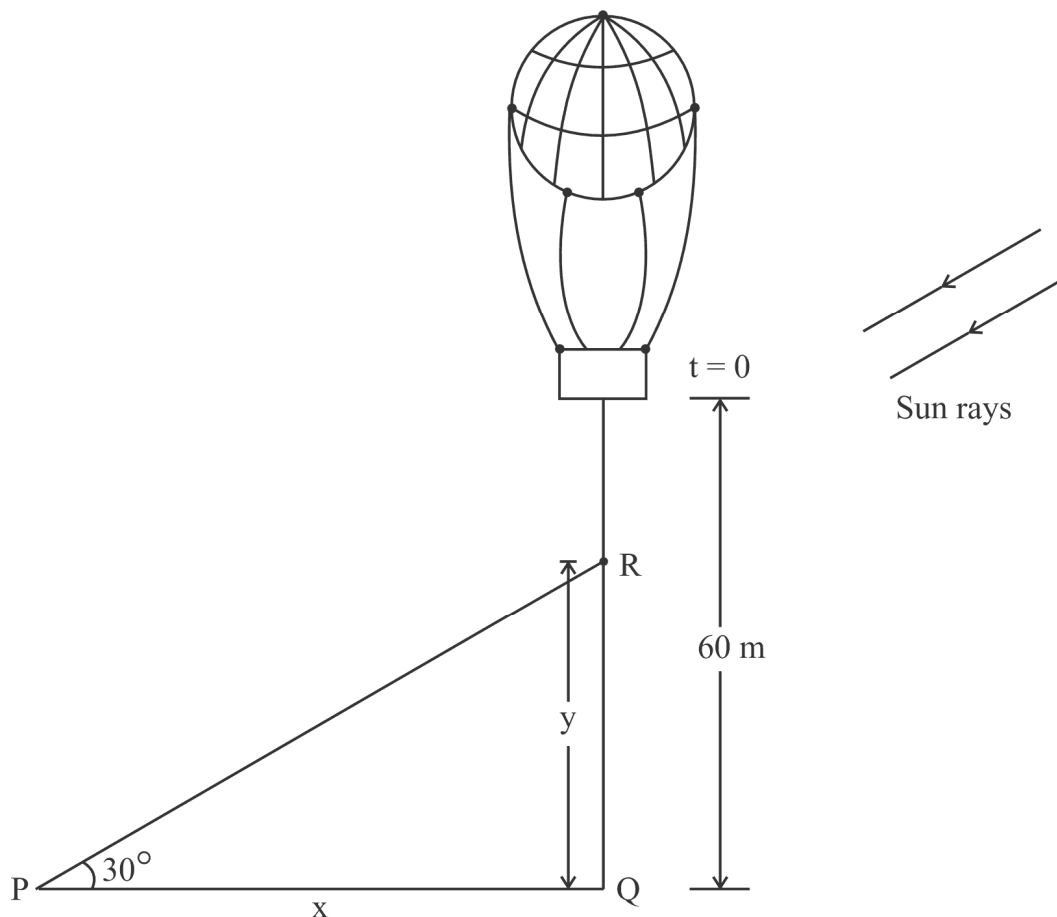

Shadow path →

When the angle of elevation of the sun is 30° , the position of the sandbag is given by the equation $y = 60 - 4.9t^2$, where y is the height of the sandbag above the ground and t is the time in seconds.

On the basis of the above information, answer the following questions :

- (i) Find the relation between x and y , where x is the distance of the shadow at P from the point Q and y is the height of the sandbag above the ground.
- (ii) After how much time will the sandbag be 35 metres above the ground ?
- (iii) (a) Find the rate at which the shadow of the sandbag is travelling along the ground when the sandbag is at a height of 35 metres.

OR

- (iii) (b) How fast is the height of the sandbag decreasing when 2 seconds have elapsed ?



प्रकरण अध्ययन – 3

38. एक विक्रेता को निश्चित दैनिक आय के अलावा हर उस बिक्री पर कमीशन मिलता है, जो वह बेचता है। वह एक दिन में जितनी संख्या की बिक्री करता है, उनकी प्रायिकताओं के साथ नीचे दी गई तालिका में दी गई है :

X :	0	1	2	3	4	5
P(X) :	0.42	3k	0.3	0.05	2k	0.03

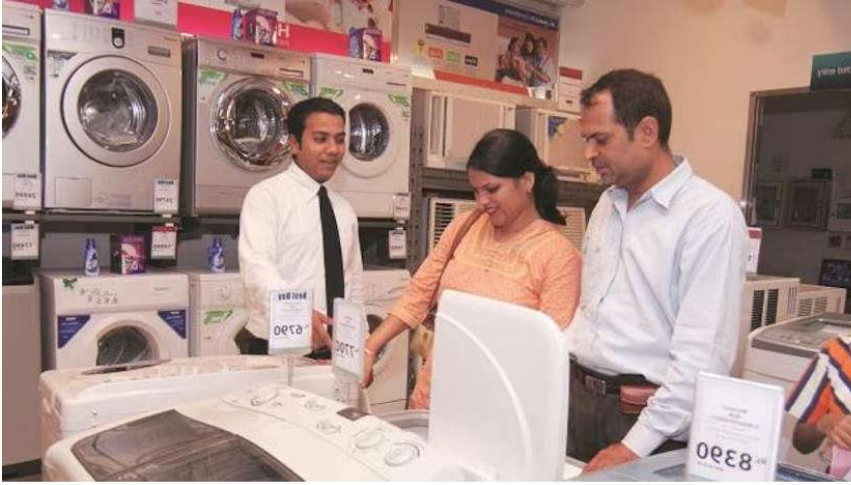

उसकी दैनिक आय Y (₹ में), इस प्रकार प्रदत्त है :

$$Y = 800X + 50$$

उपर्युक्त सूचना के आधार पर, निम्नलिखित प्रश्नों के उत्तर दीजिए :

- k का मान ज्ञात कीजिए।
- $P(X \geq 3)$ का मान ज्ञात कीजिए।
- (क) विक्रेता की अपेक्षित साप्ताहिक आय की गणना कीजिए, यह मानते हुए कि वह सप्ताह में पाँच दिन काम करता है।

अथवा

- (ख) विक्रेता की अपेक्षित साप्ताहिक आय की गणना कीजिए, यह मानते हुए कि वह सप्ताह में केवल तीन दिन काम करता है।



Case Study – 3

38. A salesman receives a commission for each sale he makes together with a fixed daily income. The number of sales he makes in a day along with their probabilities are given in the table below :

X :	0	1	2	3	4	5
P(X) :	0.42	3k	0.3	0.05	2k	0.03

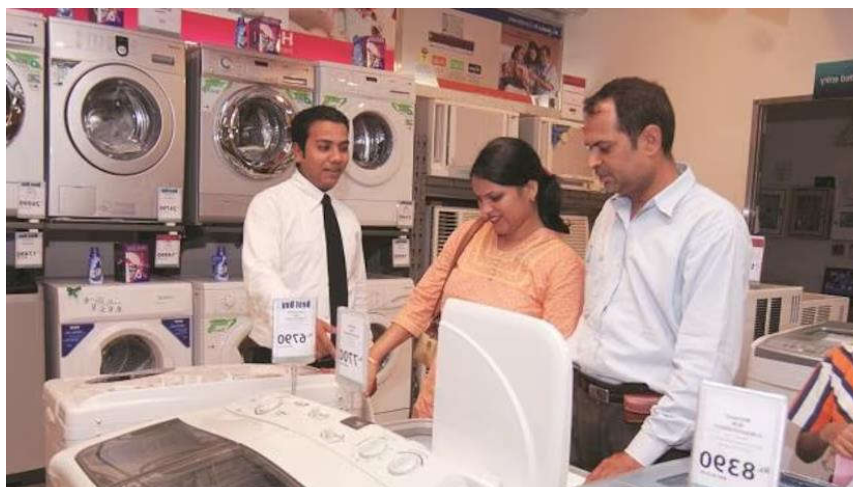

His daily income Y (in ₹) is given by :

$$Y = 800X + 50$$

On the basis of the above information, answer the following questions :

- (i) Find the value of k.
- (ii) Evaluate $P(X \geq 3)$.
- (iii) (a) Calculate the expected weekly income of the salesman assuming he works five days per week.

OR

- (iii) (b) Calculate the expected weekly income of the salesman assuming he works only for three days of the week.



Marking Scheme
Strictly Confidential
(For Internal and Restricted use only)
Senior School Certificate Examination, 2024
MATHEMATICS PAPER CODE - 65/S/2(Comp.)

General Instructions: -

1	You are aware that evaluation is the most important process in the actual and correct assessment of the candidates. A small mistake in evaluation may lead to serious problems which may affect the future of the candidates, education system and teaching profession. To avoid mistakes, it is requested that before starting evaluation, you must read and understand the spot evaluation guidelines carefully.
2	“Evaluation policy is a confidential policy as it is related to the confidentiality of the examinations conducted, Evaluation done and several other aspects. Its’ leakage to public in any manner could lead to derailment of the examination system and affect the life and future of millions of candidates. Sharing this policy/document to anyone, publishing in any magazine and printing in News Paper/Website etc may invite action under various rules of the Board and IPC.”
3	Evaluation is to be done as per instructions provided in the Marking Scheme. It should not be done according to one’s own interpretation or any other consideration. Marking Scheme should be strictly adhered to and religiously followed. However, while evaluating, answers which are based on latest information or knowledge and/or are innovative, they may be assessed for their correctness otherwise and due marks be awarded to them.
4	The Marking scheme carries only suggested value points for the answers These are in the nature of Guidelines only and do not constitute the complete answer. The students can have their own expression and if the expression is correct, the due marks should be awarded accordingly.
5	The Head-Examiner must go through the first five answer books evaluated by each evaluator on the first day, to ensure that evaluation has been carried out as per the instructions given in the Marking Scheme. If there is any variation, the same should be zero after deliberation and discussion. The remaining answer books meant for evaluation shall be given only after ensuring that there is no significant variation in the marking of individual evaluators.
6	Evaluators will mark(√) wherever answer is correct. For wrong answer CROSS ‘X’ be marked. Evaluators will not put right (✓)while evaluating which gives an impression that answer is correct and no marks are awarded. This is most common mistake which evaluators are committing.
7	If a question has parts, please award marks on the right-hand side for each part. Marks awarded for different parts of the question should then be totaled up and written in the left-hand margin and encircled. This may be followed strictly.
8	If a question does not have any parts, marks must be awarded in the left-hand margin and encircled. This may also be followed strictly.
9	<u>In Q1-Q20, if a candidate attempts the question more than once (without canceling the previous attempt), marks shall be awarded for the first attempt only and the other answer scored out with a note “Extra Question”.</u>



10	<u>In Q21-Q38, if a student has attempted an extra question, answer of the question deserving more marks should be retained and the other answer scored out with a note “Extra Question”.</u>
11	No marks to be deducted for the cumulative effect of an error. It should be penalized only once.
12	A full scale of marks _____(example 0 to 80/70/60/50/40/30 marks as given in Question Paper) has to be used. Please do not hesitate to award full marks if the answer deserves it.
13	Every examiner has to necessarily do evaluation work for full working hours i.e., 8 hours every day and evaluate 20 answer books per day in main subjects and 25 answer books per day in other subjects (Details are given in Spot Guidelines).This is in view of the reduced syllabus and number of questions in question paper.
14	Ensure that you do not make the following common types of errors committed by the Examiner in the past:- <ul style="list-style-type: none"> ● Leaving answer or part thereof unassessed in an answer book. ● Giving more marks for an answer than assigned to it. ● Wrong totaling of marks awarded on an answer. ● Wrong transfer of marks from the inside pages of the answer book to the title page. ● Wrong question wise totaling on the title page. ● Wrong totaling of marks of the two columns on the title page. ● Wrong grand total. ● Marks in words and figures not tallying/not same. ● Wrong transfer of marks from the answer book to online award list. ● Answers marked as correct, but marks not awarded. (Ensure that the right tick mark is correctly and clearly indicated. It should merely be a line. Same is with the X for incorrect answer.) Half or a part of answer marked correct and the rest as wrong, but no marks awarded.
15	While evaluating the answer books if the answer is found to be totally incorrect, it should be marked as cross (X) and awarded zero (0)Marks.
16	Any un assessed portion, non-carrying over of marks to the title page, or totaling error detected by the candidate shall damage the prestige of all the personnel engaged in the evaluation work as also of the Board. Hence, in order to uphold the prestige of all concerned, it is again reiterated that the instructions be followed meticulously and judiciously.
17	The Examiners should acquaint themselves with the guidelines given in the “ Guidelines for spot Evaluation ” before starting the actual evaluation.
18	Every Examiner shall also ensure that all the answers are evaluated, marks carried over to the title page, correctly totaled and written in figures and words.
19	The candidates are entitled to obtain photocopy of the Answer Book on request on payment of the prescribed processing fee. All Examiners/Additional Head Examiners/Head Examiners are once again reminded that they must ensure that evaluation is carried out strictly as per value points for each answer as given in the Marking Scheme.



MARKING SCHEME – 65/S/2

Q.No.	EXPECTED ANSWER / VALUE POINTS	Marks
SECTION-A (Question nos. 1 to 18 are Multiple choice Questions carrying 1 mark each)		
1.	<p>If A and B are two square matrices of order 2 and $A = 2$ and $B = 5$, then $-3AB$ is :</p> <p>(A) -90 (B) -30 (C) 30 (D) 90</p>	
Ans	(D) 90	1
2.	<p>$\int \frac{x-3}{(x-1)^3} e^x dx$ is equal to :</p> <p>(A) $\frac{2e^x}{(x-1)^3} + C$ (B) $\frac{-2e^x}{(x-1)^2} + C$ (C) $\frac{e^x}{(x-1)} + C$ (D) $\frac{e^x}{(x-1)^2} + C$</p>	
Ans	(D) $\frac{e^x}{(x-1)^2} + C$	1
3.	<p>The area (in sq. units) of the region bounded by the curve $y = x$, x-axis, $x = 0$ and $x = 2$ is :</p> <p>(A) $\frac{3}{2}$ (B) $\frac{1}{2} \log 2$ (C) 2 (D) 4</p>	
Ans	(C) 2	1



4.	<p>What is the value of $\frac{\text{projection of } \vec{a} \text{ on } \vec{b}}{\text{projection of } \vec{b} \text{ on } \vec{a}}$</p> <p>for vectors $\vec{a} = 2\hat{i} - 3\hat{j} - 6\hat{k}$ and $\vec{b} = 2\hat{i} - 2\hat{j} + \hat{k}$?</p> <p>(A) $\frac{3}{7}$ (B) $\frac{7}{3}$</p> <p>(C) $\frac{4}{3}$ (D) $\frac{4}{7}$</p>	
Ans	(B) $\frac{7}{3}$	1
5.	<p>If \vec{a} and \vec{b} are two vectors such that $\vec{a} \cdot \vec{b} > 0$ and $\vec{a} \cdot \vec{b} = \vec{a} \times \vec{b}$, then the angle between \vec{a} and \vec{b} is :</p> <p>(A) $\frac{\pi}{4}$ (B) $\frac{\pi}{3}$</p> <p>(C) $\frac{2\pi}{3}$ (D) $\frac{3\pi}{4}$</p>	
Ans	(A) $\frac{\pi}{4}$	1
6.	<p>For two matrices A and B, given that $A^{-1} = \frac{1}{4}B$, then inverse of (4A) is :</p> <p>(A) 4B (B) B</p> <p>(C) $\frac{1}{4}B$ (D) $\frac{1}{16}B$</p>	
Ans	(D) $\frac{1}{16}B$	1
7.	<p>If $x = at^2$ and $y = 2at$, then $\frac{dy}{dx}$ is equal to :</p> <p>(A) 2at (B) $\frac{1}{t}$</p> <p>(C) $-\frac{1}{t^2}$ (D) $-\frac{1}{2at^3}$</p>	



Ans	(B) $\frac{1}{t}$	1
8.	<p>The function $f(x) = x - x$ where $x \in \mathbb{R}$ is :</p> <p>(A) continuous and differentiable at $x = 0$</p> <p>(B) continuous but not differentiable at $x = 0$</p> <p>(C) not continuous but differentiable at $x = 0$</p> <p>(D) neither continuous nor differentiable at $x = 0$</p>	
Ans	(B) continuous but not differentiable at $x = 0$	1
9.	<p>If X, Y and XY are matrices of order $2 \times 3, m \times n$ and 2×5 respectively, then number of elements in matrix Y is :</p> <p>(A) 6 (B) 10</p> <p>(C) 15 (D) 35</p>	
Ans	(C) 15	1
10.	<p>The number of discontinuities of the function f given by</p> $f(x) = \begin{cases} x + 2, & \text{if } x < 0 \\ e^x, & \text{if } 0 \leq x \leq 1 \\ 2 - x, & \text{if } x > 1 \end{cases}$ <p>is :</p> <p>(A) 0 (B) 1</p> <p>(C) 2 (D) 3</p>	
Ans	(C) 2	1



11.	$\int e^{3 \log x} (x^4 + 1)^{-1} dx$ is equal to : (A) $\frac{1}{4} \log (x^4 + 1) + C$ (B) $\frac{1}{4} \log \left(\frac{1}{x^4 + 1} \right) + C$ (C) $\frac{x^3}{x^4 + 1} + C$ (D) $\frac{e^x}{x^4 + 1} + C$	
Ans	(A) $\frac{1}{4} \log(x^4 + 1) + C$	1
12.	Let $y = f\left(\frac{1}{x}\right)$ and $f'(x) = x^3$. What is the value of $\frac{dy}{dx}$ at $x = \frac{1}{2}$? (A) $-\frac{1}{64}$ (B) $-\frac{1}{32}$ (C) -32 (D) -64	
Ans	(C) -32	1
13.	If $y = \log \sqrt{\sec \sqrt{x}}$, then the value of $\frac{dy}{dx}$ at $x = \frac{\pi^2}{16}$ is : (A) $\frac{1}{\pi}$ (B) π (C) $\frac{1}{2}$ (D) $\frac{1}{4}$	
Ans	(A) $\frac{1}{\pi}$	1

14.	<p>A particular solution of the differential equation $x \frac{dy}{dx} + y = 0$, when $x = 1$ and $y = 1$, is :</p> <p>(A) $y = x$</p> <p>(B) $y = e^x$</p> <p>(C) $y = \frac{1}{x}$</p> <p>(D) $y = \log x$</p>	
Ans	(C) $y = \frac{1}{x}$	1
15.	<p>The greatest integer function defined by $f(x) = [x]$, $1 < x < 3$ is not differentiable at $x =$</p> <p>(A) 0</p> <p>(B) 1</p> <p>(C) 2</p> <p>(D) $\frac{3}{2}$</p>	
Ans	(C) 2	1
16.	<p>A vector makes equal angles with positive directions of x, y and z axes. The direction cosines of the vector are :</p> <p>(A) $\frac{1}{\sqrt{3}}, \frac{1}{\sqrt{3}}, \frac{1}{\sqrt{3}}$</p> <p>(B) $\frac{-1}{\sqrt{3}}, \frac{-1}{\sqrt{3}}, \frac{1}{\sqrt{3}}$</p> <p>(C) $\frac{-1}{2}, \frac{1}{2}, \frac{-1}{2}$</p> <p>(D) $\frac{1}{\sqrt{6}}, \frac{1}{\sqrt{6}}, \frac{-2}{\sqrt{6}}$</p>	
Ans	(A) $\frac{1}{\sqrt{3}}, \frac{1}{\sqrt{3}}, \frac{1}{\sqrt{3}}$	1



17.	<p>The vector equation of the line passing through the points $(0, 0, 2)$ and $(3, -2, 5)$ is :</p> <p>(A) $\vec{r} = 2\hat{k} + \lambda(3\hat{i} + 2\hat{j} - 5\hat{k})$</p> <p>(B) $\vec{r} = 2\hat{k} + \lambda(3\hat{i} - 2\hat{j} + 5\hat{k})$</p> <p>(C) $\vec{r} = 2\hat{k} + \lambda(3\hat{i} - 2\hat{j} + 3\hat{k})$</p> <p>(D) $\vec{r} = 3\hat{i} - 2\hat{j} + 5\hat{k} + \lambda(2\hat{k})$</p>	
Ans	(C) $\vec{r} = 2\hat{k} + \lambda(3\hat{i} - 2\hat{j} + 3\hat{k})$	1
18.	<p>If the radius of a circle is increasing at the rate of 0.5 cm/s, then the rate of increase of its circumference is :</p> <p>(A) $\frac{2\pi}{3} \text{ cm/s}$ (B) $\pi \text{ cm/s}$</p> <p>(C) $\frac{4\pi}{3} \text{ cm/s}$ (D) $2\pi \text{ cm/s}$</p>	
Ans	(B) $\pi \text{ cm/s}$	1
(Question Nos. 19 & 20 are Assertion-Reason based questions of 1 mark each)		
<p><i>Questions number 19 and 20 are Assertion and Reason based questions. Two statements are given, one labelled Assertion (A) and the other labelled Reason (R). Select the correct answer from the codes (A), (B), (C) and (D) as given below.</i></p> <p>(A) Both Assertion (A) and Reason (R) are true and Reason (R) is the correct explanation of the Assertion (A).</p> <p>(B) Both Assertion (A) and Reason (R) are true, but Reason (R) is <i>not</i> the correct explanation of the Assertion (A).</p> <p>(C) Assertion (A) is true, but Reason (R) is false.</p> <p>(D) Assertion (A) is false, but Reason (R) is true.</p>		
19.	<p><i>Assertion (A) :</i> If R and S are two events such that $P(R S) = 1$ and $P(S) > 0$, then $S \subset R$.</p> <p><i>Reason (R) :</i> If two events A and B are such that $P(A \cap B) = P(B)$, then $A \subset B$.</p>	
Ans	(C) Assertion (A) is true, but Reason (R) is false.	1



20.	<p><i>Assertion (A) :</i> $\cos^{-1} \left(\cos \frac{13\pi}{6} \right)$ is equal to $\frac{\pi}{6}$.</p> <p><i>Reason (R) :</i> The range of the principal value branch of the function $y = \cos^{-1} x$ is $[0, \pi]$.</p>	
Ans	(A) Both Assertion (A) and Reason (R) are true, and Reason (R) is the correct explanation of the Assertion (A).	1
SECTION-B (Question nos. 21 to 25 are very short Answer type questions carrying 2 marks each)		
21.	<p>Evaluate :</p> $\sin^{-1} \left(\sin \frac{13\pi}{6} \right) + \cos^{-1} \left(\cos \frac{\pi}{3} \right) + \tan^{-1} (\sqrt{3})$	
Ans	$\sin^{-1} \left(\sin \frac{13\pi}{6} \right) + \cos^{-1} \left(\cos \frac{\pi}{3} \right) + \tan^{-1} (\sqrt{3})$ $= \frac{\pi}{6} + \frac{\pi}{3} + \frac{\pi}{3}$ $= \frac{5\pi}{6}$	$1\frac{1}{2}$ $\frac{1}{2}$
22.	Given that $f(x) = \frac{\log x}{x}$, find the point of local maximum of $f(x)$.	
Ans	$f'(x) = \frac{1 - \log x}{x^2}, \therefore f'(x) = 0 \Rightarrow \log x = 1 \Rightarrow x = e$ $f''(x) = \frac{2x \log x - 3x}{x^4} \Rightarrow f''(e) = -\frac{1}{e^3} < 0 \text{ i.e. } x = e \text{ is a point of local maximum.}$	 1 1
23.	<p>(a) Find :</p> $\int \frac{x^3 - 1}{x^3 - x} dx$ <p style="text-align: center;">OR</p> <p>(b) Evaluate :</p> $\int_{-4}^0 x + 2 dx$	

Ans	<p>(a) $\int \frac{x^3-1}{x^3-x} dx = \int \left(1 + \frac{1}{x} - \frac{1}{x+1}\right) dx$ $= x + \log x - \log x+1 + c$</p> <p style="text-align: center;">Or</p> <p>(b) $\int_{-4}^0 x+2 dx = \int_{-4}^{-2} -(x+2) dx + \int_{-2}^0 (x+2) dx$ $= -\left[\frac{(x+2)^2}{2}\right]_{-4}^{-2} + \left[\frac{(x+2)^2}{2}\right]_{-2}^0 = 2 + 2 = 4$</p>	1 1 1 1
24.	<p>(a) If $y = (\sin^{-1} x)^2$, then find $(1-x^2) \frac{d^2y}{dx^2} - x \frac{dy}{dx}$.</p> <p style="text-align: center;">OR</p> <p>(b) If $y^x = x^y$, then find $\frac{dy}{dx}$.</p>	
Ans	<p>(a) $\frac{dy}{dx} = \frac{2\sin^{-1} x}{\sqrt{1-x^2}} \Rightarrow (1-x^2) \left(\frac{dy}{dx}\right)^2 = 4y$ Differentiating with respect to 'x', we get $(1-x^2) 2 \frac{dy}{dx} \frac{d^2y}{dx^2} - 2x \left(\frac{dy}{dx}\right)^2 = 4 \frac{dy}{dx}$ $\Rightarrow (1-x^2) \frac{d^2y}{dx^2} - x \frac{dy}{dx} = 2$</p> <p style="text-align: center;">Or</p> <p>(b) $y^x = x^y \Rightarrow x \log y = y \log x$ Differentiating with respect to 'x', $\frac{x}{y} \frac{dy}{dx} + \log y = \frac{y}{x} + \frac{dy}{dx} \log x$ $\Rightarrow \frac{dy}{dx} = \frac{y}{x} \left(\frac{y - x \log y}{x - y \log x}\right)$</p>	1 $\frac{1}{2}$ $\frac{1}{2}$ $\frac{1}{2}$ 1 $\frac{1}{2}$
25.	Find the value of k so that the lines joining the points (1, -1, 2) and (3, 4, k) is perpendicular to the line joining the points (0, 3, 2) and (3, 5, 6).	



Ans	The direction ratios of the two lines are: $2, 5, k-2$ and $3, 2, 4$ respectively. The lines are perpendicular $\therefore, 2(3) + 5(2) + 4(k-2) = 0 \Rightarrow k = -2$	1 1
SECTION-C (Question nos. 26 to 31 are short Answer type questions carrying 3 marks each)		
26.	It is known that 20% of the students in a school have above 90% attendance and 80% of the students are irregular. Past year results show that 80% of students who have above 90% attendance and 20% of irregular students get 'A' grade in their annual examination. At the end of a year, a student is chosen at random from the school and is found to have an 'A' grade. What is the probability that the student is irregular ?	
Ans	<p>Let B : Student getting 'A' grade E_1 : Student having above 90% attendance E_2 : Student being irregular</p> $P(E_1) = \frac{20}{100}; P(E_2) = \frac{80}{100} \quad P(B E_1) = \frac{80}{100}; P(B E_2) = \frac{20}{100}$ $P(E_2 A) = \frac{P(E_2)P(B E_2)}{P(E_1)P(B E_1) + P(E_2)P(B E_2)}$ $= \frac{0.8 \times 0.2}{0.2 \times 0.8 + 0.8 \times 0.2} = \frac{1}{2}$	<p style="text-align: right;">} $\frac{1}{2}$</p> <p style="text-align: right;">$1\frac{1}{2}$</p> <p style="text-align: right;">$\frac{1}{2}$</p> <p style="text-align: right;">$\frac{1}{2}$</p>
27.	<p>(a) If $y = \cos^{-1} \left(\frac{1-x^2}{1+x^2} \right)$, $0 < x < 1$, then find $\frac{dy}{dx}$.</p> <p style="text-align: center;">OR</p> <p>(b) If $x^y = e^{x-y}$, prove that $\frac{dy}{dx} = \frac{\log x}{\{\log(xe)\}^2}$.</p>	

Ans	<p>(a) $y = \cos^{-1}\left(\frac{1-x^2}{1+x^2}\right)$, Put $x = \tan \theta \Rightarrow \theta = \tan^{-1} x$</p> <p>$\Rightarrow y = \cos^{-1}(\cos 2\theta) = 2\theta = 2 \tan^{-1} x, \therefore \frac{dy}{dx} = \frac{2}{1+x^2}$</p> <p style="text-align: center;">Or</p> <p>(b) $x^y = e^{x-y} \Rightarrow y \log x = x - y \Rightarrow y = \frac{x}{\log x + 1}$</p> <p>$\Rightarrow \frac{dy}{dx} = \frac{\log x}{(\log x + 1)^2} = \frac{\log x}{\{\log(xe)\}^2}$</p>	1 2 1 2
28.	<p>(a) Find a matrix A such that</p> $A \begin{bmatrix} 4 & 0 \\ -1 & -2 \end{bmatrix} = \begin{bmatrix} 17 & 10 \\ 0 & -16 \end{bmatrix}.$ <p>Also, find A^{-1}.</p> <p style="text-align: center;">OR</p> <p>(b) Given a square matrix A of order 3 such that $A^2 = \begin{bmatrix} 3 & -4 & 4 \\ 0 & -1 & 0 \\ -2 & 2 & -3 \end{bmatrix}$,</p> <p>show that $A^3 = A^{-1}$.</p>	
Ans	<p>(a) $A = \begin{bmatrix} 17 & 10 \\ 0 & -16 \end{bmatrix} \begin{bmatrix} 4 & 0 \\ -1 & -2 \end{bmatrix}^{-1}$</p> <p>$= -\frac{1}{8} \begin{bmatrix} 17 & 10 \\ 0 & -16 \end{bmatrix} \begin{bmatrix} -2 & 0 \\ 1 & 4 \end{bmatrix}$</p> <p>$= \begin{bmatrix} 3 & -5 \\ 2 & 8 \end{bmatrix}$</p> <p>Also, $A^{-1} = \frac{1}{34} \begin{bmatrix} 8 & 5 \\ -2 & 3 \end{bmatrix}$</p> <p style="text-align: center;">Or</p>	$\frac{1}{2}$ 1 $\frac{1}{2}$ 1

	<p>(b) $A^3 = A^{-1} \Leftrightarrow A^4 = I$</p> $A^4 = A^2 A^2 = \begin{bmatrix} 3 & -4 & 4 \\ 0 & -1 & 0 \\ -2 & 2 & -3 \end{bmatrix} \begin{bmatrix} 3 & -4 & 4 \\ 0 & -1 & 0 \\ -2 & 2 & -3 \end{bmatrix} = \begin{bmatrix} 1 & 0 & 0 \\ 0 & 1 & 0 \\ 0 & 0 & 1 \end{bmatrix} = I$	<p>$1\frac{1}{2}$</p> <p>$1\frac{1}{2}$</p>
29.	<p>Find the particular solution of the differential equation :</p> $x \cos y \, dy = (x e^x \log x + e^x) \, dx \text{ given that } y = \frac{\pi}{2} \text{ when } x = 1.$	
Ans	<p>Separating the variables and integrating:</p> $\int \cos y \, dy = \int e^x \left(\log x + \frac{1}{x} \right) dx$ $\Rightarrow \sin y = e^x \log x + c$ <p>Using $y = \frac{\pi}{2}, x = 1$, we get $c = 1$</p> <p>\therefore the particular solution is, $\sin y = 1 + e^x \log x$</p>	<p>1</p> <p>1</p> <p>$\frac{1}{2}$</p> <p>$\frac{1}{2}$</p>
30.	<p>Show that the vectors $3\hat{i} + \hat{j} - 2\hat{k}$, $2\hat{i} - \hat{j} - 8\hat{k}$ and $4\hat{i} - 2\hat{j} - 7\hat{k}$ form the vertices of a right triangle.</p>	
Ans	<p>Let $A(3\hat{i} + \hat{j} - 2\hat{k})$, $B(2\hat{i} - \hat{j} - 8\hat{k})$, and $C(4\hat{i} - 2\hat{j} - 7\hat{k})$, then</p> $\overline{AB} = -\hat{i} - 2\hat{j} - 6\hat{k}, \overline{BC} = 2\hat{i} - \hat{j} + \hat{k}, \overline{CA} = -\hat{i} + 3\hat{j} + 5\hat{k} \text{ and } \overline{AB} + \overline{BC} + \overline{CA} = \vec{0}$ $\overline{BC} \cdot \overline{CA} = -2 - 3 + 5 = 0 \Rightarrow \overline{BC} \perp \overline{CA}, \therefore ABC \text{ is a right triangle.}$	<p>2</p> <p>1</p>

31.	<p>(a) Find :</p> $\int \frac{dx}{\cos x \sqrt{\cos 2x}}$ <p style="text-align: center;">OR</p> <p>(b) Find :</p> $\int \frac{5x-3}{\sqrt{1+4x-2x^2}} dx$	
Ans	<p>(a) $\int \frac{dx}{\cos x \sqrt{\cos 2x}} = \int \frac{dx}{\cos x \sqrt{\cos^2 x - \sin^2 x}}$</p> $= \int \frac{\sec^2 x}{\sqrt{1 - \tan^2 x}} dx$ $= \int \frac{1}{\sqrt{1-t^2}} dt, \text{ using } \tan x = t, \sec^2 x \cdot dx = dt$ $= \sin^{-1} t + c = \sin^{-1}(\tan x) + c$ <p style="text-align: center;">Or</p> <p>(b) $\int \frac{5x-3}{\sqrt{1+4x-2x^2}} dx = -\frac{5}{4} \int \frac{-4x+4}{\sqrt{1+4x-2x^2}} dx + \sqrt{2} \int \frac{1}{\sqrt{\left(\left(\frac{\sqrt{3}}{2}\right)^2 - (x-1)^2\right)}} dx$</p> $= -\frac{5}{2} \sqrt{1+4x-2x^2} + \sqrt{2} \sin^{-1} \left(\sqrt{\frac{2}{3}} (x-1) \right) + c$	<p>$\frac{1}{2}$</p> <p>1</p> <p>$\frac{1}{2}$</p> <p>1</p> <p>$1\frac{1}{2}$</p> <p>$1\frac{1}{2}$</p>
SECTION-D (Question nos. 32 to 35 are Long Answer type questions carrying 5 marks each)		
32.	<p>Check whether the relation S in the set \mathbb{R} of real numbers, defined as $S = \{(a, b) : a \leq b^2\}$ is reflexive, symmetric or transitive. Also, determine all $x \in \mathbb{R}$ such that $(x, x) \in S$.</p>	
Ans	<p>Reflexive: Let $\frac{1}{2} \not\leq \left(\frac{1}{2}\right)^2$, $\therefore S$ is not reflexive.</p> <p>Symmetric: $1 \leq 2^2 \Rightarrow (1, 2) \in S$ but $2 \not\leq 1^2 \Rightarrow (2, 1) \notin S$. $\therefore S$ is not symmetric.</p>	<p>1</p> <p>$1\frac{1}{2}$</p>



Transitive: $10 \leq 6^2 \Rightarrow (10, 6) \in S$ & $6 \leq 3^2 \Rightarrow (6, 3) \in S$ but $10 \not\leq 3^2 \Rightarrow (10, 3) \notin S$
 $\therefore S$ is not Transitive.

Let $(x, x) \in S \Leftrightarrow x \leq x^2 \Leftrightarrow x \in \mathbf{R} - (0, 1)$

1 1/2

1

33.

Solve the following linear programming problem graphically :

Minimise $Z = 6x + 7y$

subject to constraints

$x + 2y \geq 240$

$3x + 4y \leq 620$

$2x + y \geq 180$

$x, y \geq 0.$

Ans

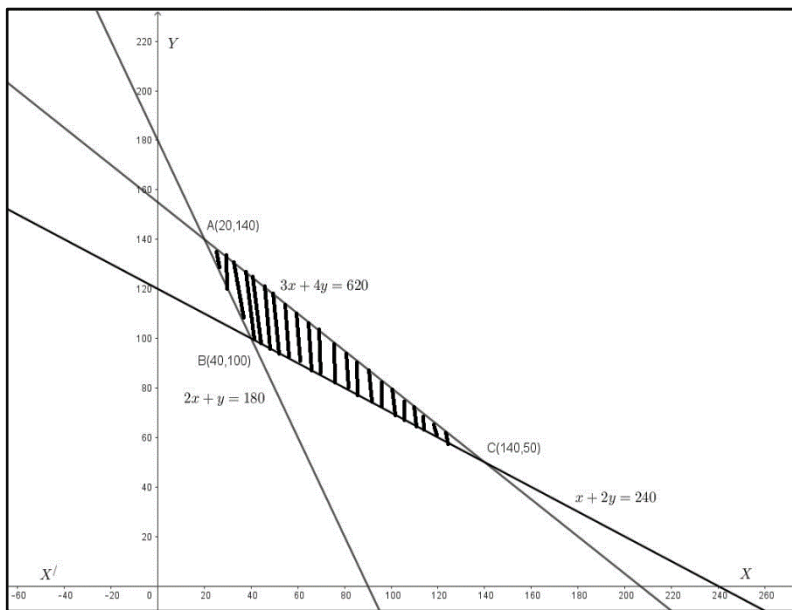

Correct Graph

3 1/2

Corner Points	Value of $Z = 6x + 7y$
A (20, 140)	$Z = 1100$
B (40, 100)	$Z = 940$
C (140, 50)	$Z = 1190$

1

1/2

$\text{Min}(Z) = 940$ at $x = 40, y = 100$



34. (a) Using integration, find the area of the region bounded by the curve $y = \sqrt{4-x^2}$, the lines $x = -\sqrt{2}$ and $x = \sqrt{3}$ and the x-axis.

OR

- (b) Using integration, evaluate the area of the region bounded by the curve $y = x^2$, the lines $y = 1$ and $y = 3$ and the y-axis.

Ans

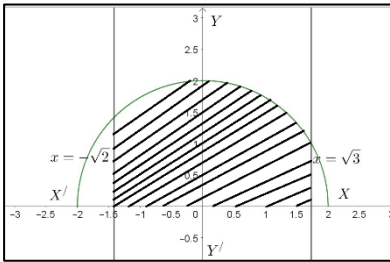

Correct Graph

1

Area of the region bounded by the curve

$$\begin{aligned}
 &= \int_{-\sqrt{2}}^{\sqrt{3}} \sqrt{4-x^2} dx \\
 &= \left[\frac{x}{2} \sqrt{4-x^2} + 2 \sin^{-1} \frac{x}{2} \right]_{-\sqrt{2}}^{\sqrt{3}} \\
 &= \frac{\sqrt{3}}{2} + 2 \cdot \frac{\pi}{3} + 1 + 2 \cdot \frac{\pi}{4} = \frac{\sqrt{3}}{2} + 1 + \frac{7\pi}{6}
 \end{aligned}$$

$1\frac{1}{2}$

$1\frac{1}{2}$

1

Or

Correct Graph

1

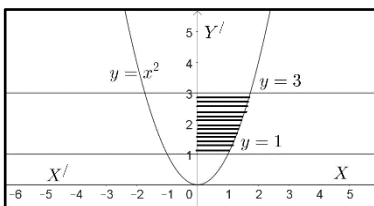

Area of the region bounded by the curve

$$\begin{aligned}
 &= \int_1^3 \sqrt{y} dy \\
 &= \left[\frac{2y^{3/2}}{3} \right]_1^3 = \frac{2}{3} (3\sqrt{3} - 1)
 \end{aligned}$$

2

2



35.	<p>(a) Find the shortest distance between the lines $\frac{x-8}{3} = \frac{y+9}{-16} = \frac{z-10}{7}$ and $\frac{x-15}{3} = \frac{y-29}{8} = \frac{z-5}{-5}$.</p> <p style="text-align: center;">OR</p> <p>(b) Find the point of intersection of the lines $\vec{r} = \hat{i} - \hat{j} + 6\hat{k} + \lambda(3\hat{i} - \hat{k})$, and $\vec{r} = -3\hat{j} + 3\hat{k} + \mu(\hat{i} + 2\hat{j} - \hat{k})$.</p> <p>Also, find the vector equation of the line passing through the point of intersection of the given lines and perpendicular to both the lines.</p>	
Ans	<p>(a) $\vec{r} = (8\hat{i} - 9\hat{j} + 10\hat{k}) + \lambda(3\hat{i} - 16\hat{j} + 7\hat{k})$ $\vec{r} = (15\hat{i} + 29\hat{j} + 5\hat{k}) + \mu(3\hat{i} + 8\hat{j} - 5\hat{k})$ } We have, $\vec{a}_1 = 8\hat{i} - 9\hat{j} + 10\hat{k}$, $\vec{b}_1 = 3\hat{i} - 16\hat{j} + 7\hat{k}$, $\vec{a}_2 = 15\hat{i} + 29\hat{j} + 5\hat{k}$, $\vec{b}_2 = 3\hat{i} + 8\hat{j} - 5\hat{k}$ $\vec{a}_2 - \vec{a}_1 = 7\hat{i} + 38\hat{j} - 5\hat{k}$, $\vec{b}_1 \times \vec{b}_2 = \begin{vmatrix} \hat{i} & \hat{j} & \hat{k} \\ 3 & -16 & 7 \\ 3 & 8 & -5 \end{vmatrix} = 24\hat{i} + 36\hat{j} + 72\hat{k}$ $\text{Shortest Distance} = \frac{ (\vec{b}_1 \times \vec{b}_2) \cdot (\vec{a}_2 - \vec{a}_1) }{ \vec{b}_1 \times \vec{b}_2 } = \frac{98}{7} = 14$ <p style="text-align: center;">Or</p> <p>If the given lines intersect then, $\hat{i} - \hat{j} + 6\hat{k} + \lambda(3\hat{i} - \hat{k}) = -3\hat{j} + 3\hat{k} + \mu(\hat{i} + 2\hat{j} - \hat{k})$ Solving the equations, $1 + 3\lambda = \mu$, $-1 = 2\mu - 3$, we get $\lambda = 0$, $\mu = 1$ which do not satisfy the equation, $6 - \lambda = 3 - \mu$. \therefore The lines do not intersect, hence no point of intersection</p> </p>	<p style="text-align: right;">2</p> <p style="text-align: right;">$\frac{1}{2} + 1\frac{1}{2}$</p> <p style="text-align: right;">1</p> <p style="text-align: right;">1</p> <p style="text-align: right;">2</p> <p style="text-align: right;">1</p> <p style="text-align: right;">1</p>
SECTION-E		

(Question nos. 36 to 38 are source based/case based/passage based/integrated units of assessment questions carrying 4 marks each)

36.

An architect is developing a plot of land for a commercial complex. When asked about the dimensions of the plot, he said that if the length is decreased by 25 m and the breadth is increased by 25 m, then its area increases by 625 m^2 . If the length is decreased by 20 m and the breadth is increased by 10 m, then its area decreases by 200 m^2 .

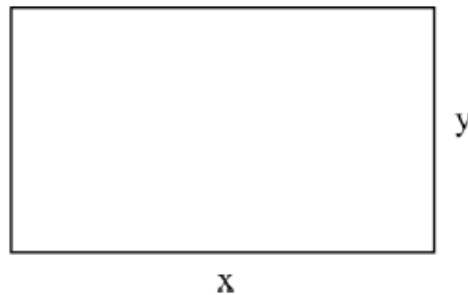

On the basis of the above information, answer the following questions :

- Formulate the linear equations in x and y to represent the given information.
- Find the dimensions of the plot of land by matrix method.

Ans

$$(i) (x - 25)(y + 25) = xy + 625 \Rightarrow x - y = 50$$

$$(x - 20)(y + 10) = xy - 200 \Rightarrow x - 2y = 0$$

(ii) The system of linear equations can be written in matrix form as

$$\begin{bmatrix} 1 & -1 \\ 1 & -2 \end{bmatrix} \begin{bmatrix} x \\ y \end{bmatrix} = \begin{bmatrix} 50 \\ 0 \end{bmatrix}$$

$$\Rightarrow \begin{bmatrix} x \\ y \end{bmatrix} = \begin{bmatrix} 1 & -1 \\ 1 & -2 \end{bmatrix}^{-1} \begin{bmatrix} 50 \\ 0 \end{bmatrix} = - \begin{bmatrix} -2 & 1 \\ -1 & 1 \end{bmatrix} \begin{bmatrix} 50 \\ 0 \end{bmatrix} = \begin{bmatrix} 100 \\ 50 \end{bmatrix}$$

$$x = 100\text{m}, y = 50\text{m}$$

1

1

 $\frac{1}{2}$

1

 $\frac{1}{2}$

37.

A sandbag is dropped from a balloon at a height of 60 metres.

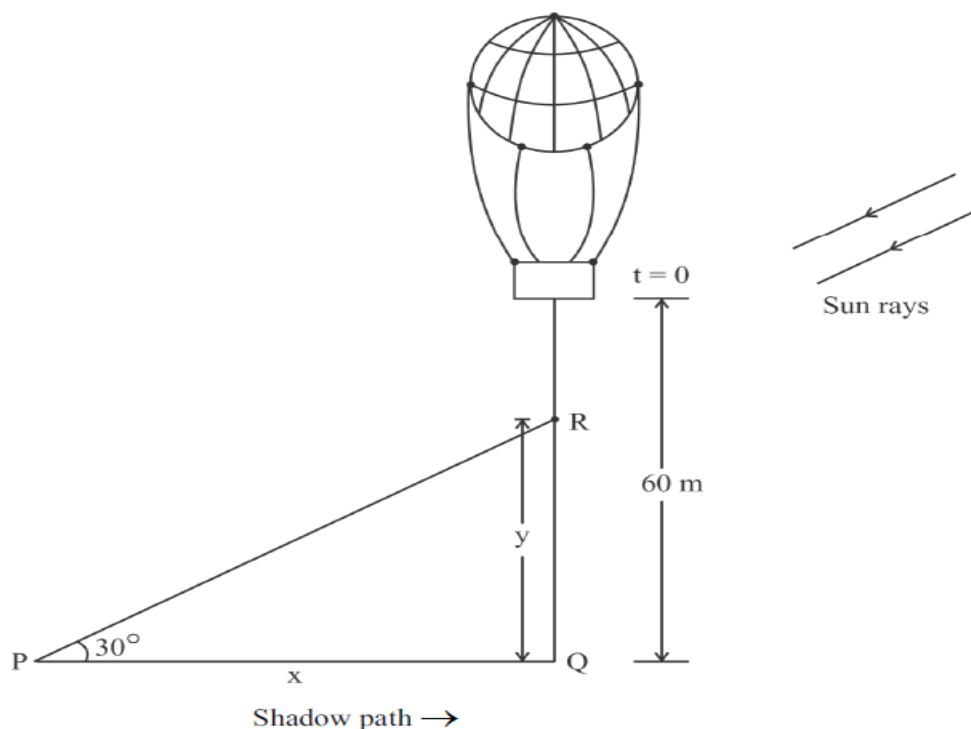

When the angle of elevation of the sun is 30° , the position of the sandbag is given by the equation $y = 60 - 4.9t^2$, where y is the height of the sandbag above the ground and t is the time in seconds.

On the basis of the above information, answer the following questions :

- (i) Find the relation between x and y , where x is the distance of the shadow at P from the point Q and y is the height of the sandbag above the ground.
- (ii) After how much time will the sandbag be 35 metres above the ground ?
- (iii) (a) Find the rate at which the shadow of the sandbag is travelling along the ground when the sandbag is at a height of 35 metres.

OR

- (iii) (b) How fast is the height of the sandbag decreasing when 2 seconds have elapsed ?

Ans

(i) $\frac{y}{x} = \tan 30^\circ \Rightarrow y = \frac{x}{\sqrt{3}}$ or $x = \sqrt{3}y$

(ii) Using $y = 35\text{m} \Rightarrow 60 - 4.9t^2 = 35 \Rightarrow 4.9t^2 = 25 \Rightarrow t = \frac{5\sqrt{10}}{7}$ seconds.

(iii) (a) $x = \sqrt{3}y \Rightarrow x = 60\sqrt{3} - 4.9\sqrt{3}t^2 \Rightarrow \frac{dx}{dt} \Big|_{t=\frac{5\sqrt{10}}{7}} = -4.9\sqrt{3}(2t) \Big|_{t=\frac{5\sqrt{10}}{7}} = -7\sqrt{30}$ m/s

Or

(iii) (b) $\frac{dy}{dt} = -9.8t = -9.8 \times 2 = -19.6$ m/s

1

1

2

2

Height of the sandbag is decreasing at the rate of 19.6 m/s

38.

A salesman receives a commission for each sale he makes together with a fixed daily income. The number of sales he makes in a day along with their probabilities are given in the table below :

X :	0	1	2	3	4	5
P(X) :	0.42	3k	0.3	0.05	2k	0.03



His daily income Y (in ₹) is given by :

$$Y = 800X + 50$$

On the basis of the above information, answer the following questions :

- (i) Find the value of k .
- (ii) Evaluate $P(X \geq 3)$.
- (iii) (a) Calculate the expected weekly income of the salesman assuming he works five days per week.

OR

- (iii) (b) Calculate the expected weekly income of the salesman assuming he works only for three days of the week.



Ans	(i) $0.42 + 3k + 0.3 + 0.05 + 2k + 0.03 = 1 \Rightarrow 5k = 0.2 \Rightarrow k = \frac{1}{25} = 0.04$	1
	(ii) $P(X \geq 3) = 0.05 + 2k + 0.03 = 2k + 0.08 = 0.08 + 0.08 = 0.16$	1
	(iii) (a) Expected sales per day = $\sum x \cdot P(x)$ $= 3k + 0.6 + 0.15 + 8k + 0.15 = 11k + 0.9 = 1.34$	1
	Expected Daily income = $Y = 800(1.34) + 50 = ₹ 1122$	$\frac{1}{2}$
	Expectedly sales income for five days per week = ₹ 5610	$\frac{1}{2}$
	Or	
	(iii) (b) Expected sales per day = $\sum x \cdot P(x)$ $= 3k + 0.6 + 0.15 + 8k + 0.15 = 11k + 0.9 = 1.34$	1
	Expected Daily income = $Y = 800(1.34) + 50 = ₹ 1122$	$\frac{1}{2}$
	Expectedly sales income for three days of the week = ₹ 3366	$\frac{1}{2}$

